



3428 Vane Court, Suite C, Charlotte, NC 28206

ph: 704-376-8500 fax: 704-376-8003

www.theamsn.com

## DOME & NAVY CAPS/STUDS

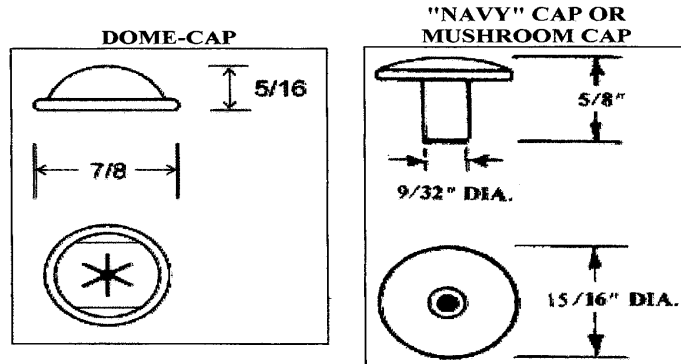

Material	Application
Aluminum with spring steel insert	Designed to conceal exposed points on GEM CO 12 ga. weld pins or insulation hangers.
Aluminum	Designed for use with AMSN Navy 3/16" annular ring weld pins and Navy insulation hanger pin.
Mild Steel (galv.)	Designed to be used with AMSN pronged hanger.

### CD Annular Grooved (Navy) Weld Pins - 3/16" Dia.

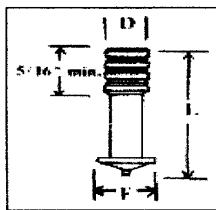

CD ANNULAR GROOVED WELD PIN SPECIFICATIONS					
MATERIAL	FINISH	"D"	"L"	MILD STEEL / STAINLESS STEEL "F"	ALUM. "F"
Low Carbon Steel Aluminum	Mild Steel pins are copper coated. Other coatings quoted upon request.	.1875 (3/16")	7/8" 1-7/8" 2-7/8"	.250	.250

**COMPATIBILITY:** All pins are compatible and recommended for use with all brands of CD stud welding equipment.

**Disclaimer:** This information contained herein is believed to be accurate and correct. However, no warranty, implied or expressed, is made, regarding its accuracy or the results to be obtained from the use of this information.